

Four Suction Cup Climbing Robot

◆ Alvin Arman ◆ Angie Leitner ◆ Kyle Williams ◆ Jay Blanchard ◆ Brian Andres ◆

Challenges

1. Adhesion to all surface types
2. Moment
3. Synchronized motion
4. Mounted weight

Solutions

1. Bellowed suction cups
2. Parallel alignment of two pairs of suction cups
3. Intelligent controls
4. Hanger for added weight, outer protective housing, bungee strap.

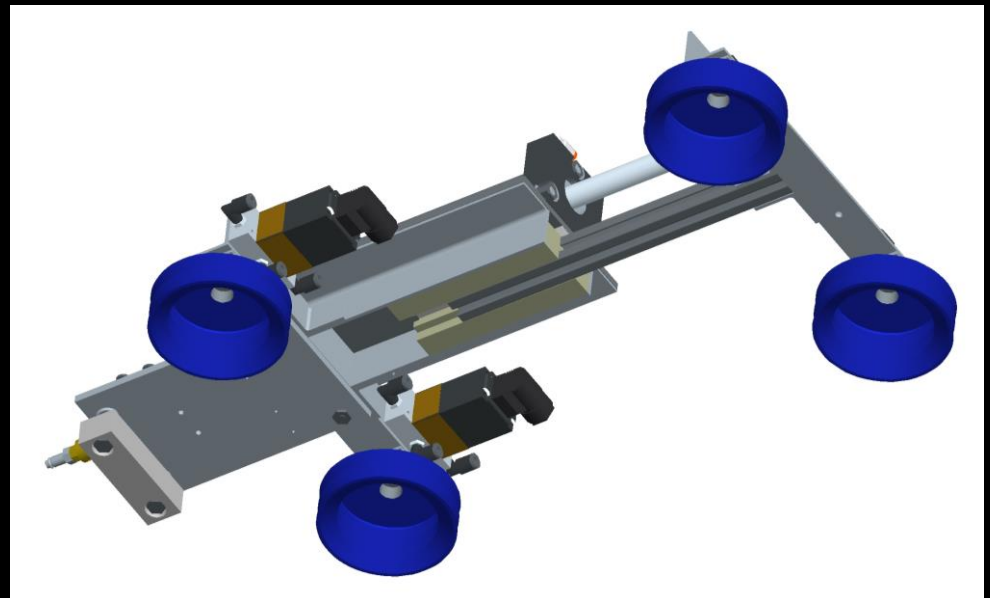
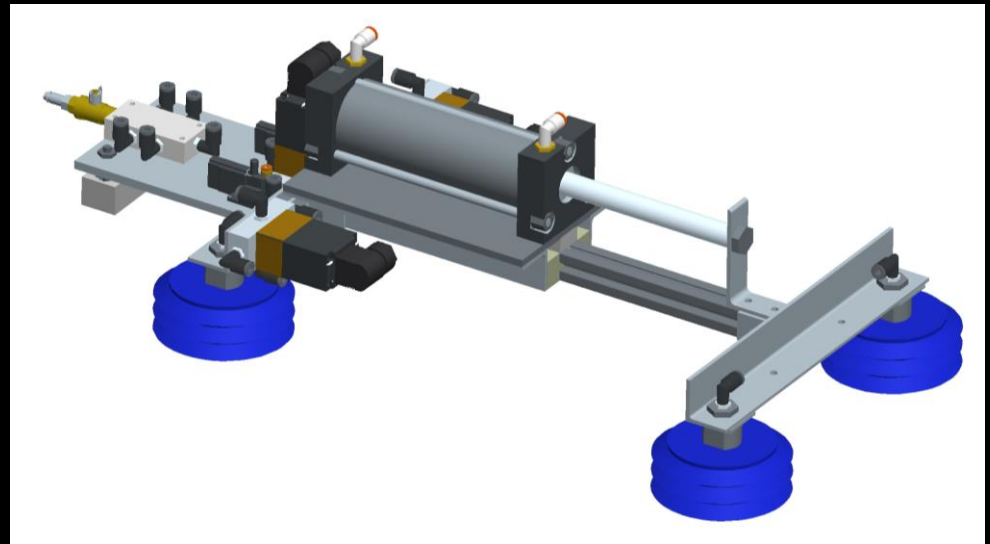

Vertically Challenged

